

REDUCING COUPLING FORGED STEEL ASTM A105 CLASS 3000 SW



Design: ANSI B16.11
Socket Welding
Material: Forged Steel ASTM A105
Class: 3000
Correlation: Schedule 80 / XS

Nominal Pipe Size	W	D	Approx. Weight
inch			kg
1/2" x 1/4"	28.96	31.24	0.13
1/2" x 3/8"	28.96	31.24	0.12
3/4" x 1/8"	35.05	37.08	0.20
3/4" x 1/4"	35.05	37.08	0.19
3/4" x 3/8"	35.05	37.08	0.19
3/4" x 1/2"	35.05	37.08	0.18
1" x 1/4"	38.10	45.21	0.36
1" x 3/8"	38.10	45.21	0.35
1" x 1/2"	38.10	45.21	0.34
1" x 3/4"	38.10	45.21	0.33
1 1/4" x 1/2"	38.10	54.86	0.41
1 1/4" x 3/4"	38.10	54.86	0.40
1 1/4" x 1"	38.10	54.86	0.39
1 1/2" x 1/4"	38.10	61.47	0.60
1 1/2" x 3/8"	38.10	61.47	0.59
1 1/2" x 1/2"	38.10	61.47	0.58
1 1/2" x 3/4"	38.10	61.47	0.57
1 1/2" x 1"	38.10	61.47	0.54
1 1/2" x 1 1/4"	38.10	61.47	0.52
2" x 1/2"	50.80	75.18	0.91
2" x 3/4"	50.80	75.18	0.88
2" x 1"	50.80	75.18	0.87
2" x 1 1/4"	50.80	75.18	0.85
2" x 1 1/2"	50.80	75.18	0.84
2 1/2" x 1/2"	50.80	93.98	1.25
2 1/2" x 3/4"	50.80	93.98	1.22
2 1/2" x 1"	50.80	93.98	1.20
2 1/2" x 1 1/4"	50.80	93.98	1.18
2 1/2" x 1 1/2"	50.80	93.98	1.16
2 1/2" x 2"	50.80	93.98	1.13
3" x 1"	50.80	109.22	1.72
3" x 1 1/4"	50.80	109.22	1.70
3" x 1 1/2"	50.80	109.22	1.68
3" x 2"	50.80	109.22	1.66
3" x 2 1/2"	50.80	109.22	1.63
4" x 1 1/2"	57.15	136.91	2.72
4" x 2"	57.15	136.91	2.68
4" x 2 1/2"	57.15	136.91	2.63
4" x 3"	57.15	136.91	2.59

Units: Millimeters (mm)

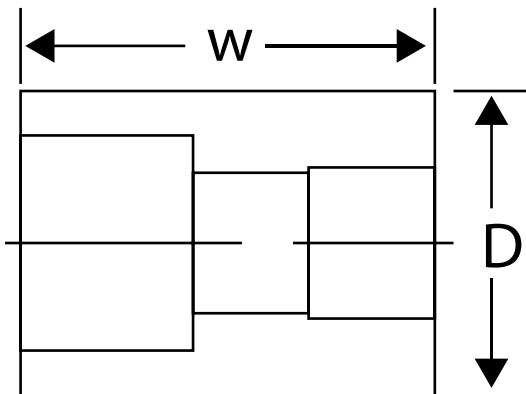

CONTÁCTANOS

 Lautaro 2083 2097
Lote 5, Concepción

 ventas@wenganindustrial.cl

 +56 9 8731 4484

 www.wenganindustrial.cl

SÍGUENOS EN
REDES SOCIALES

